



*Specialist for Pumping Technology*



**VTP**

**Vertical Turbine Pump**

# 70 years developing the pumping technology that drives progress

Ruhrpumpen is an innovative and efficient pump technology company that offers highly engineered, custom made solutions for oil & gas, chemical processing, power generation, industrial applications and water.

Implementation of cutting-edge technology and world-class engineering, combined with our unique vertically integrated structure, allows Ruhrpumpen to design complex technical solutions, creating the most robust and powerful pump systems in the marketplace.

Our broad product line complies with the most demanding quality standards and industry specifications such as **American Petroleum Institute (API)**, **American National Standards Institute (ANSI)**, **Underwriter's Laboratories (UL)**, **Factory Mutual (FM)**, **National Fire Protection Association (NFPA)**, **ISO** and **Hydraulic Institute**.

### Products include:

- Single stage overhung pumps
- Vertical in-line pumps
- Single and multi-stage between bearing pumps
- Multi-stage vertical pumps
- Reciprocating plunger pumps
- Sealless magnetic drive pumps
- Fire protection systems
- Pitot tube pumps
- Hydraulic decoking systems



### Ruhrpumpen is your single source supplier

- Original Equipment
- Spare parts
- Installation and startup support
- Repair and maintenance
- Engineering, training and consulting
- Reverse engineering

### Benefits of our pumps:

- Proven reliability
- High efficiency designs ensure lowest operating cost
- Robust design allows for long system life with minimal maintenance
- Optimized total cost of ownership

## Vertical Turbine Pumps

**VTP pumps** are normally designed to operate in wells or sumps. The bowl assembly consists of a suction case or bell, one or more series cases, impeller assemblies, and a discharge case. The number of stages (impellers) supplied is determined by the head requirements of the system. The pump bowl assembly is positioned in the sump or well at a depth to provide the proper intake configuration.

Qualified specialists in all departments ensure that the pumps and equipment from our facilities are able to operate under the most arduous conditions.

Intensive research and development ensure that the products of Ruhrpumpen are continuously improved to meet the latest technical requirements. The instant availability of spare parts, together with first class service, ensures customers that they have selected the right partner.



Selection Chart VTP

Various Poles  
 — 50 Hz — 60 Hz

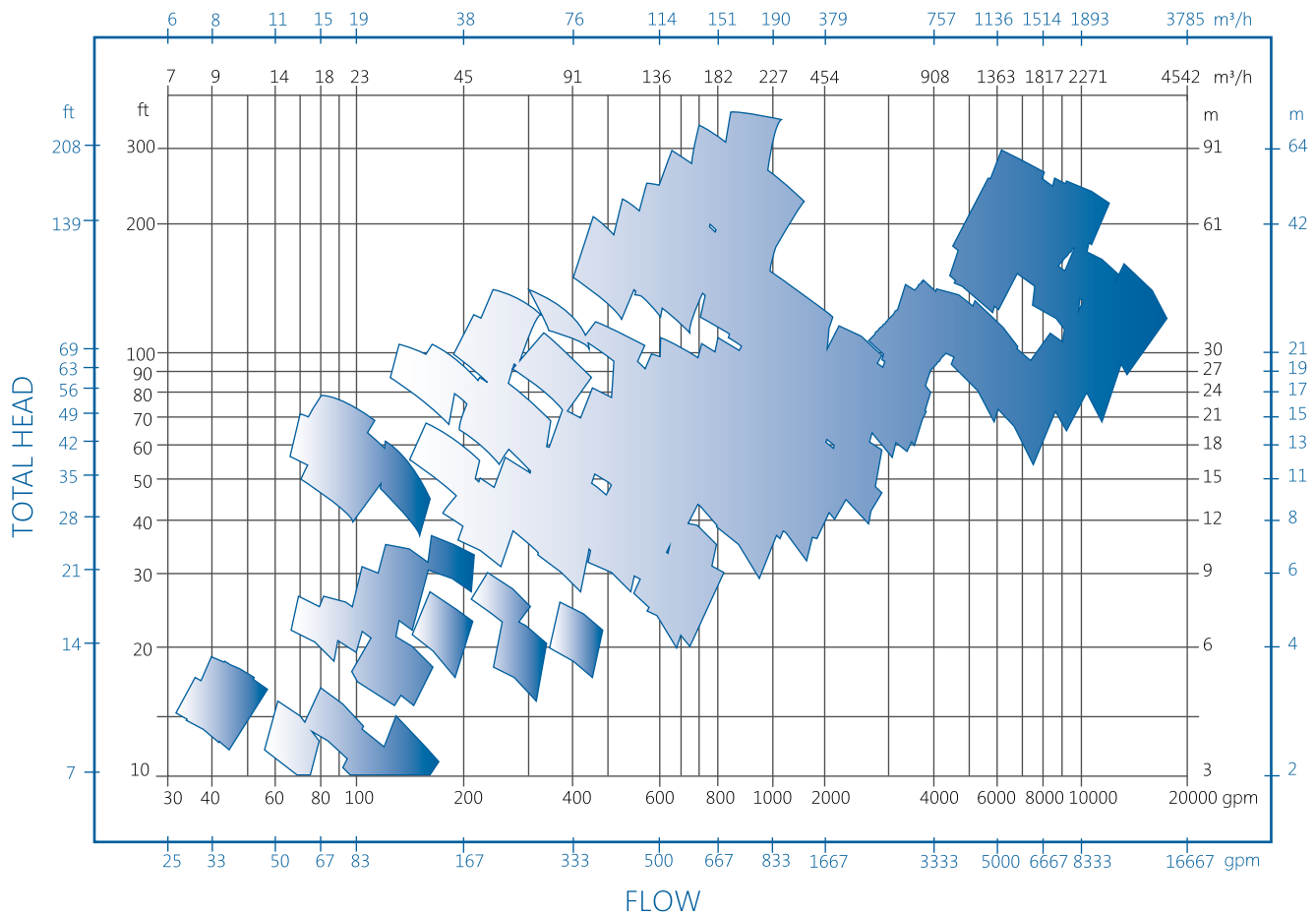

## Ruhrpumpen helps it's customers save money on existing pumps with Synergetic Retrofit®

Besides the more common mechanical retrofits, Ruhrpumpen also offers power retrofits (including impellers) to improve operations and save money on energy. This might be necessary when pump operating conditions have been changed, if we have excessive wear ring clearances or there might even be new (better) techniques in the market. Ruhrpumpen developed the Synergetic Retrofit® method to adapt existing pump installations to new operating conditions, improve efficiency and save power by replacing or redesigning impellers and wear rings.

Ruhrpumpen Water Pumps  
 City of Brantford  
 (Ontario, Canada)



# VERTICAL TURBINE PUMP

## Characteristics

- 1 Discharge head provides support for entire pump and column assembly as well as the driver. Available in cast iron, fabricated steel or a variety of optional materials.
- 2 Columns are flanged or threaded and available as product lubricated or with enclosing tubes for oil or water flushed lubrication.
- 3 Column assemblies are manufactured to assure accurate fit and are available in a variety of materials and coatings.
- 4 Line shafts are turned, ground, and polished carbon steel with ends faced and threaded. Other materials available for special applications.
- 5 The suction bell is cast iron with integral straightening vanes to prevent turbulence. Other materials available for special applications. The suction case is provided for deep well pump applications.
- 6 Basket or conical strainer (optional) prevents entry of foreign objects into pump suction.
- 7 Machined stuffing box with bushing to maintain proper shaft alignment.
- 8 Bearings are standard in bronze and are also available in a variety of other materials to meet client needs.
- 9 Shaft couplings bored and threaded from precision forged steel bar.

- The open lineshaft construction allows the lineshaft bearings to be lubricated by pumped liquid.
- Optional is the prelubrication system prior to the start-up of pump.

## VTP with enclosed Lineshaft

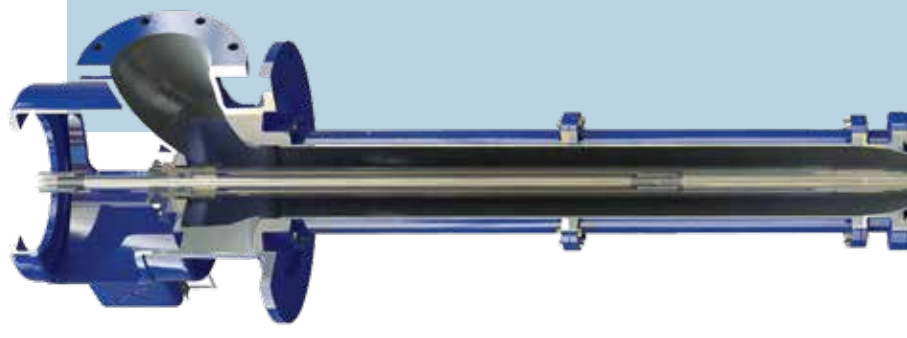
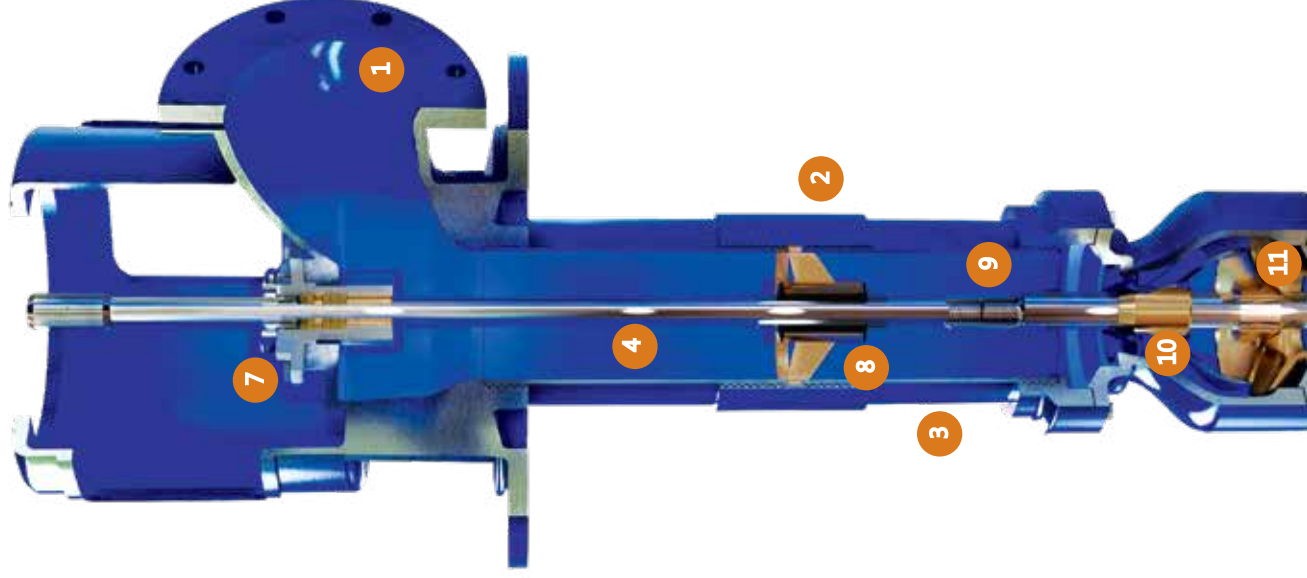

- 10** Sleeve bearings operate in conjunction with pump shaft to provide proper alignment and maintain hydraulic clearances.
- 11** Enclosed impellers are designed for long life and high efficiency. Each is precision machined and balanced for vibration free operation. Semi-open impellers available on certain models.
- 12** Standard tapered collets secure impeller to pump shaft.
- 13** The sand collar prevents grit from entering the suction bell bearing.
- 14** With the grease plug the suction bell is permanently grease packed which ensures trouble-free life.



## BELOW GROUND DISCHARGE

When using a fabricated discharge design, the Ruhrpumpen pumps are also available with the discharge located underground.

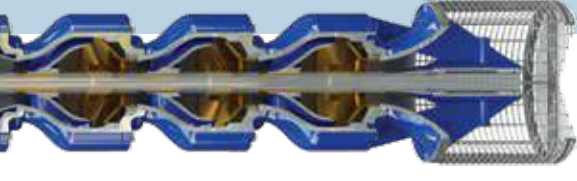

Also available with enclosed lineshaft for external lubrication (grease/oil)

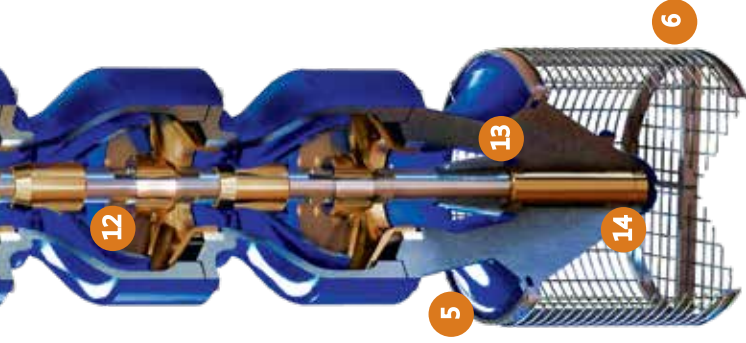

Optional construction features include bowl and impeller wear rings for extended impeller life. Keyed impellers for ease of disassembly and thrust balancing to put less strain on the driver assembly.



Enclosed impeller design maintains high efficiency and eliminates critical field adjustments required with semi-open or open impeller construction.



Standard cast iron bowl construction provides maximum wear resistance and reduced friction.

-Images for illustration purposes not actual construction.



# VERTICAL TURBINE PUMP

## Description

### PRODUCT DESCRIPTION

- Multi-stage vertical centrifugal pumps with diffuser type bowl.
- Collet mounted Semi-Open / enclosed impellers.
- Counter clockwise rotation viewed from coupling end.
- Product or oil/grease lubricated.
- Oversized bowl shaft sizing for longer life.
- API 610 latest edition construction available. API pump type VS1.
- Basket or conical strainer (optional), according to pump requirements.
- Epoxy coated bowls.
- The VTP can be supplied with submersible motor (optional).

### BROAD APPLICATION RANGE

- Deep Well
- Irrigation
- Sump
- Condensate
- Can pump requirements
- Fire service
- Municipal
- Industrial

### PERFORMANCE DATA

Capacity	up to 13,636 m <sup>3</sup> /h	60,000 U.S. gpm
Head	up to 762 m	2,500 ft
Pressure	up to 74 bar	1,080 psig
Temperature	up to 121 °C	250 °F

Note: For pump operation outside this range, please contact a Ruhrpumpen representative.



### AVAILABLE FOR FIRE SERVICE

Ruhrpumpen's vertical turbine fire pumps are listed by Underwriter's Laboratories Inc and approved by Factory Mutual.

- NFPA-20
- UL-448
- FM-1312
- Special design available on request



### SUBMERSIBLE VTP PUMPS

Ruhrpumpen offers submersible pumps for applications such as:

- High temperature wells
- Wells with limited diameter
- Projects where appearance prohibits surface installation
- Agricultural irrigation
- Deep-well de-watering
- City water supplies and large construction sites
- Others



## Other Ruhrpumpen Products



### ANSI Horizontal Process Pump

Single-stage, radially split casing with flanged connections, enclosed impeller, foot mounted.  
Petrochemical, Oil & Gas, Steel Industry, Automotive, Power Generation, Water Treatment, Pharmaceutical and General Process.



### Sump Pump

Vertical arrangement, single suction, single stage.  
Water, Hydrocarbons and Chemical solutions.



### Barge Vertical Pump

Multi-stage, pollution prevention design, semi-open impellers, primary self-priming 1st stage impeller, air relief and separation chamber.  
Ballast Operation, transfer of Gasoline, Fuel Oils, Light Lubricants, Heavy oils and Barge Stripping / Dewatering.



### Horizontal Split Case Pump

Single stage double suction, Enclosed Impeller, Double suction provides hydraulic balance eliminating axial thrust.  
Dewatering, Mining, Water Industry, Fire Service, Cooling Towers, Petrochemical, Power Generation, Municipal and Other applications.



With every project you can count on **QUALITY, SERVICE, EXPERTISE, INNOVATION** and **COMPETITIVENESS**.  
Because we have a commitment with each customer, the community and the world.  
We are Ruhrpumpen the specialist for pumping technology!

## +65 years creating the pumping technology that moves our world

Ruhrpumpen is an innovative and efficient pump technology company that offers highly-engineered and standard pumping solutions for the oil & gas, power generation, industrial, water and chemical markets. We offer a broad range of centrifugal and reciprocating pumps that meet and exceed the requirements of the most demanding quality specifications and industry standards such as API, ANSI, UL, FM, ISO and Hydraulic Institute.

